

siegling prolink

modular belts

Recommendations for constructing and calculating conveyors

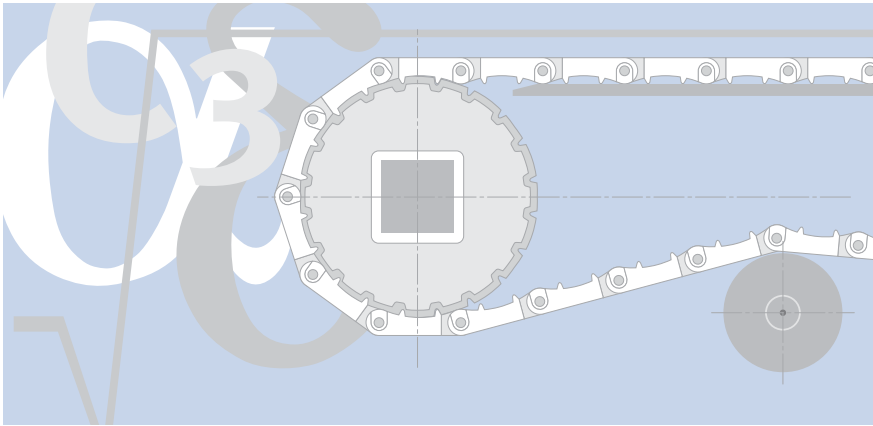

You can obtain detailed information on ProLink plastic modular belts in the overview of the range (ref. no. 223) and the data sheets on the individual series.

Content

Belt support	2
Shafts	3
Conventional conveyors	5
Reversible conveyors	6
Inclined conveyors	7
Curve conveyors	9
Spiral conveyors	10
Further information/ Effect of temperature	11
Calculation	12

Belt support

Skid plate

The belt can be supported in the following ways:

- Continuous plate support made of steel or plastics such as PE 1000. We recommend this for conveyors with heavy loads.
- Straight parallel runners (figs. 1 + 2) made of steel or plastics. This is an inexpensive solution for applications with minimal loads. The belt wear is limited to the areas where the runners support the belt. We recommend a distance of approx. 120 – 150 mm between the runners for the upper side and approx. 200 mm for the return side.
- The belt is supported over the entire width by a V-shaped arrangement of the runners (figs. 3 + 4). This spreads the wear and tear evenly and means heavy loads can be applied.
- Around the curves the belt is supported by plastic guides at the sides, for example PE 1000 or a plastic with lubricating properties, on the inner radius (see fig. 5).

Suitable plastic runners are available from specialized dealers. The width should be approx. 30 – 40 mm, whereby the thickness depends on the height of the screw heads.

The permissible temperature ranges, as given by the manufacturer, must also correspond to the expected operating conditions.

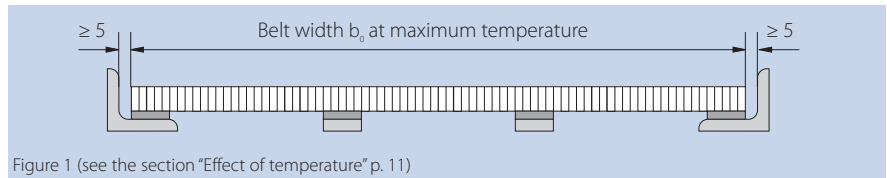

Figure 1 (see the section "Effect of temperature" p. 11)

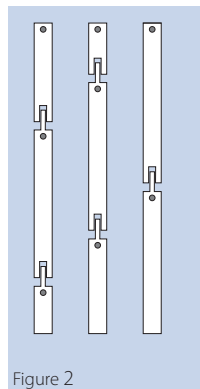

Figure 2

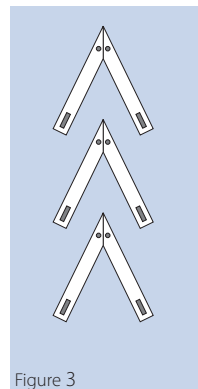

Figure 3

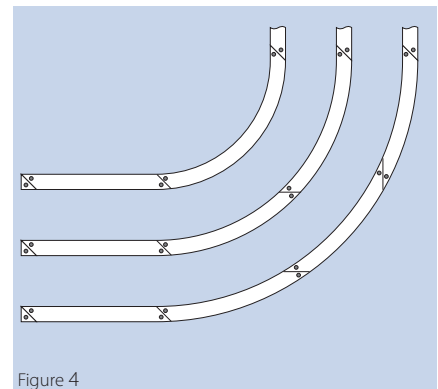

Figure 4

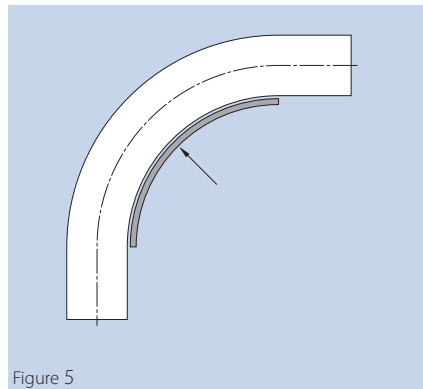

Figure 5

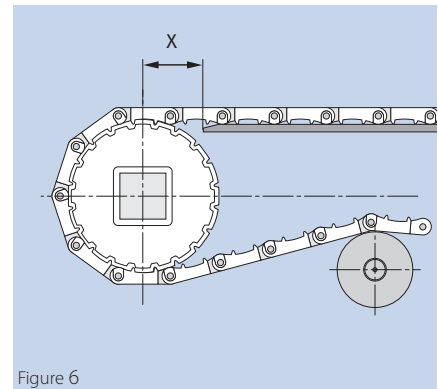

Figure 6

Thermal expansion and contraction must also be taken into consideration when mounting the support. These effects can be eliminated by slots and appropriate distancing between the runners (see the section "Effect of temperature").

- Distance $X \leq 1.5 \times \text{module pitch}$
- Place the snub roller on the return side so that the arc of contact on the drive and idle shafts $\geq 180^\circ$. (This does not apply to conveyors with $e \leq 2 \text{ m}$. Rollers on the return side are not necessary here.)

Roller support

Rollers are not generally used to support the belt on the upper face. Unavoidable belt sag between the rollers as well as the chordal action of the drive unit (see page 11) mean the goods are tipped which can cause problems. Sometimes rollers are used for conveying bulk goods.

Shafts



Drive Shaft

In general, we recommend the selection of a square shaft. The main advantage of this design is that positive drive and tracking are possible without keys and keyways. This saves on additional manufacturing costs. In addition, this form facilitates the lateral movement of the sprockets in the case of temperature variations.

Occasionally round shafts with feather keys are also used for low-loaded, narrow belts. Specially designed sprockets with bore and keyway are available.

Fastening the sprockets

Usually only 1 sprocket (as near as possible to the centre) must be fastened axially on each idle or drive shaft. The design of this sprocket enables positive tracking of the belt.

Examples of possible methods for fastening a sprocket are shown below:

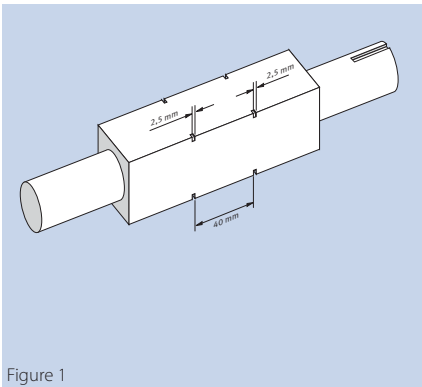

Figure 1
Shaft 40 x 40 mm
Fastening the sprocket with a retainer ring in accordance with DIN 471 (Seeger circlip ring) $d = 56$ mm.

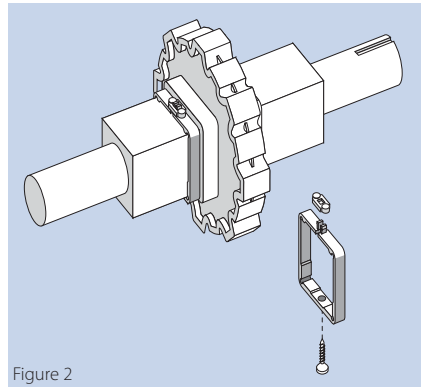

Figure 2
Self-locking plastic retainer rings that can be supplied with the sprockets.
To prevent shifting to the side (e.g. due to large lateral forces, fluctuation in temperature, etc.), the retainer rings should be secured with an additional screw.

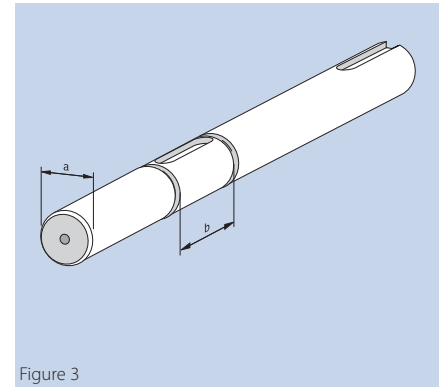

Figure 3
Fixation of the sprocket with retainer rings in accordance with DIN 471 (Seeger circlip ring).

Deflection

Large belt widths and/or high tensile loads can lead to excessive deflection, preventing perfect belt-tooth engagement in the drive area. This results in uneven stress on the teeth of the sprocket, and it is possible that the sprockets do not engage properly, leading to “jumping” of the teeth when the belt is loaded. The borderline value permitted is the tooth engagement angle α_z and depends on the shape of the gear ring and module. For the ProLink linear belts this is 1.2° .

If the borderline values are exceeded, additional intermediate bearings must be applied or a larger shaft selected.

The tooth engagement angle α_z is calculated using this formula:

$$\alpha_z = \arctan\left(\frac{y_w}{1} \cdot 2\right)$$

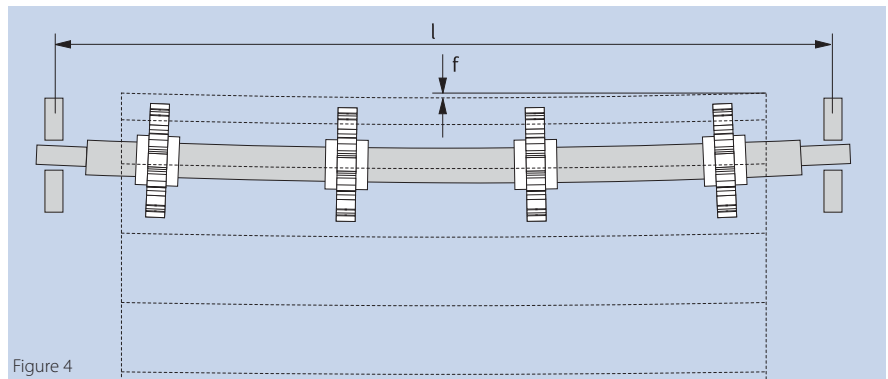

Figure 4

The shaft deflection y_w is calculated using the following formulae

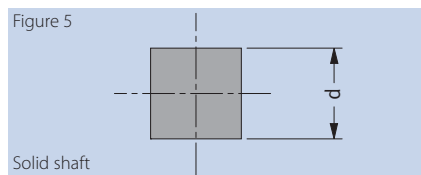

Figure 5

Solid shaft

$$y_w = 0.156 \frac{F_w \cdot l^3}{E \cdot d^4} \quad [\text{mm}]$$

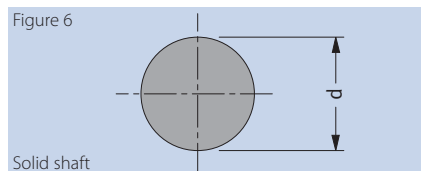

Figure 6

Solid shaft

$$y_w = \frac{80 \cdot F_w \cdot l^3}{E \cdot d^4 \cdot \pi \cdot 96} \quad [\text{mm}]$$

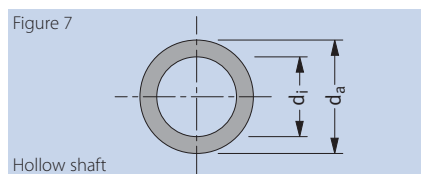

Figure 7

Hollow shaft

$$y_w = \frac{80 \cdot F_w \cdot l^3}{96 \cdot E \cdot (d_a^4 - d_i^4) \cdot \pi} \quad [\text{mm}]$$

- F_w = shaft load [N]
- l = bearing centre distance [mm]
- E = shaft's modulus of elasticity [N/mm²] (e.g. for steel = $2.1 \cdot 10^5$ N/mm²)
- d = length of side of square shaft [mm]
- d, d_i, d_a = diameter of shaft [mm]
- y_w = shaft deflection

Conventional conveyors

Belt sag/control of belt length

There are various causes for changes in the belt length, e.g.

- Elongation or contraction of the belt due to temperature variation
- Wear of the connecting rods as well as enlargement of the connecting rod holes in the modules after a certain "break-in time" (enlargement of holes, 0.5-mm larger holes in a 50 mm module result in an elongation of 1%).

Therefore we recommend not supporting one (or several) sections on the return side and using the resulting belt sag to compensate for the increase in length. It is important that perfect engagement between belt and sprocket is ensured. Following are several examples:

- Short conveyor (fig. 1)
- Medium length conveyors, up to a centre distance of approx. 4,000 mm (fig. 2)
- Long conveyors:
 - centre distance > 20,000 mm and low speeds
 - centre distance < 15,000 mm and high speeds (fig. 3)

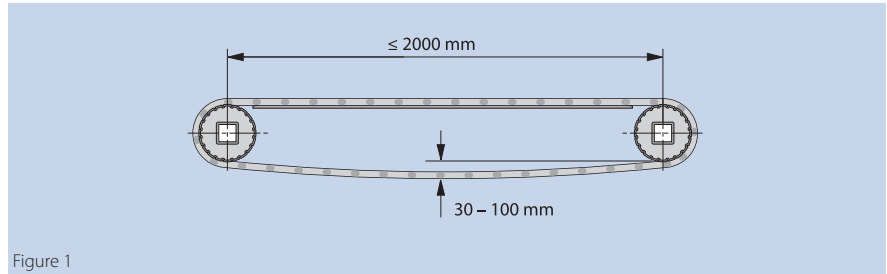

Figure 1

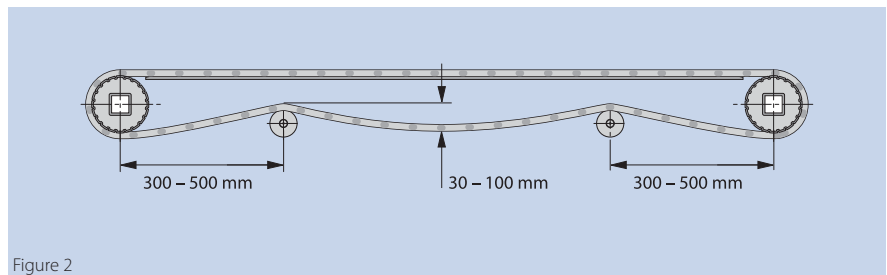

Figure 2

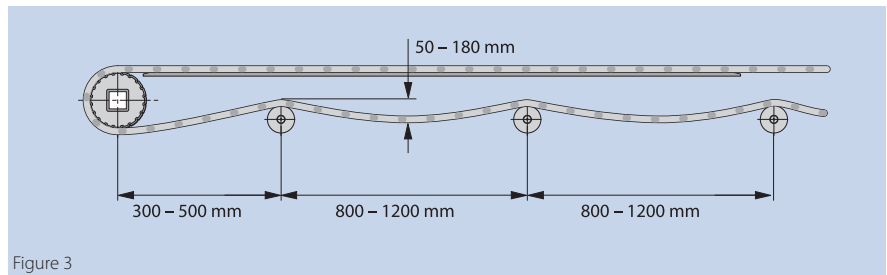

Figure 3

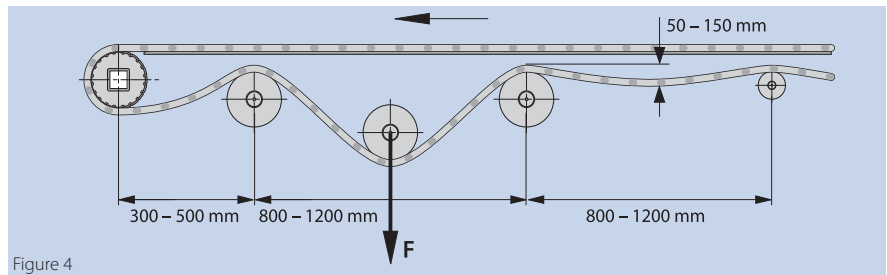

Figure 4

Another effective method for compensating for belt elongation is a load-dependent take-up system (e.g. weighted roller). This should be located as closely to the drive shaft as possible since the take-up system will ensure even tension on the return side and therefore perfect engagement between sprocket and belt (fig. 4).

For series 1, 3 and 7 we recommend a weighted roller, 150 mm in diameter and a weight of approx. 30 kg/m belt width.

For series 2 and 4 we recommend a weighted roller, 100 mm in diameter and a weight of approx. 15 kg/m belt width.

For series 6 we recommend a weighted roller, 100 mm in diameter and a weight of approx. 60 kg/m belt width.

Reversible conveyors

Two-motor design

Advantages: Low tension on the return side, making smaller shaft loads possible

Disadvantage: Increased costs due to additional motor and electronic control. For larger conveyors with relatively heavy loads, however, this system may still be the most reasonably priced.

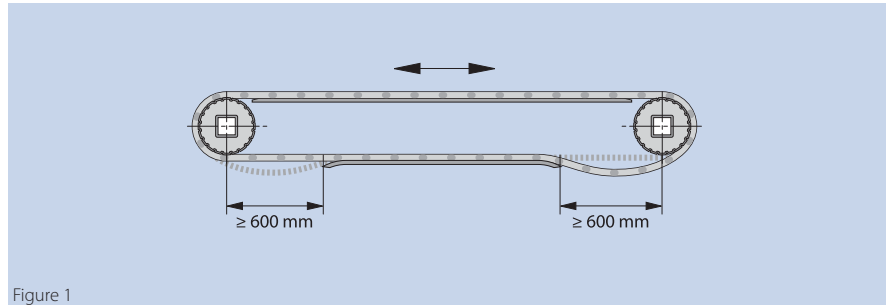

Centre drive

For reversing operation the drive shaft must be located as close to the middle as possible. To the right and the left of the drive unit, areas with belt sag are to be provided, since these are necessary for the required belt tension. The 180° arc of contact on the drive shaft means belt and sprocket engage perfectly making reliable power transmission in both operational directions possible.

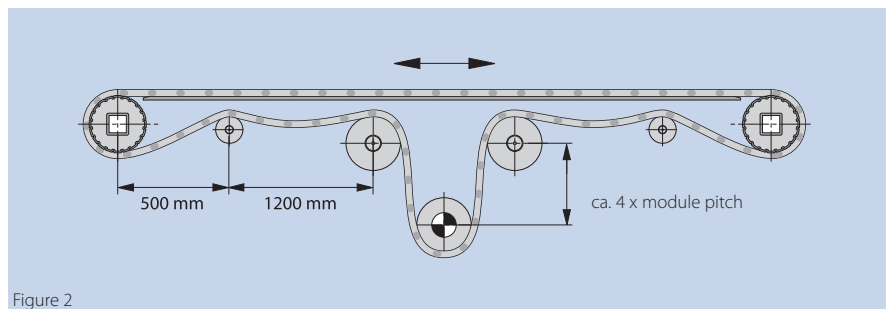

The location of the drive unit causes more stress on the shafts at the ends of the conveyor as there is effective pull on both the upper and return sides in the form of belt tension.

Alternating tail-head drive configuration

In the case of head drives the conveyor is like a conventional conveyor. It is only when conveying direction is reversed that the conveyor become tail-driven and the drive unit has to push the belt and its load. If the tension on the return side is not greater than that on the upper side it will jump sprockets.

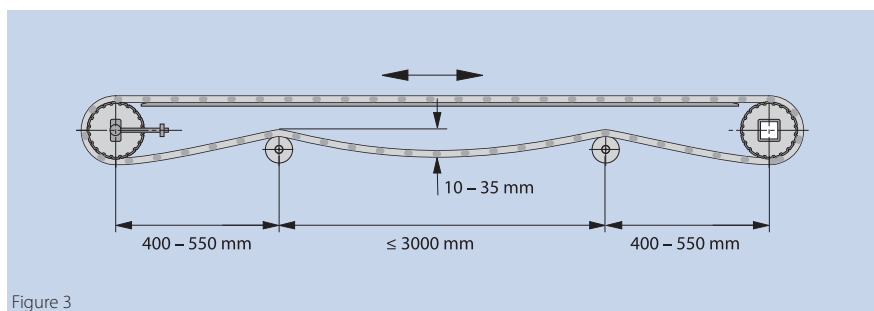

An approximate value for the tension on the return side is $1.2 - 1.3 \times F_U$. This automatically leads to a greater shaft load.

$$F_w \approx 2,2 - 2,3 \times F_U$$

Inclined conveyors

Inclined conveying

We always recommend the following:

- Only operate with a head drive, i.e. use the upper shaft as the drive shaft.
- There is always a screw-operated take-up system or a load-dependent tension take-up on the return side since tension decreases with increasing inclination (caused by the belt sag).
- If sprockets are used at upper intermediate points, the centre sprockets may not be fastened axially.
- If rollers are used at upper intermediate points, a minimum radius of approx. 80 mm is required.
- When shoe or runners are used, the radius should be as large as possible in order to keep wear to a minimum. We recommend a minimum radius of approx. 150 mm. The width of the shoe should not be smaller than 30 mm.
- If the belt is more than 600 mm wide, we recommend providing further supports on the belt surface or on the profiles on the return side.

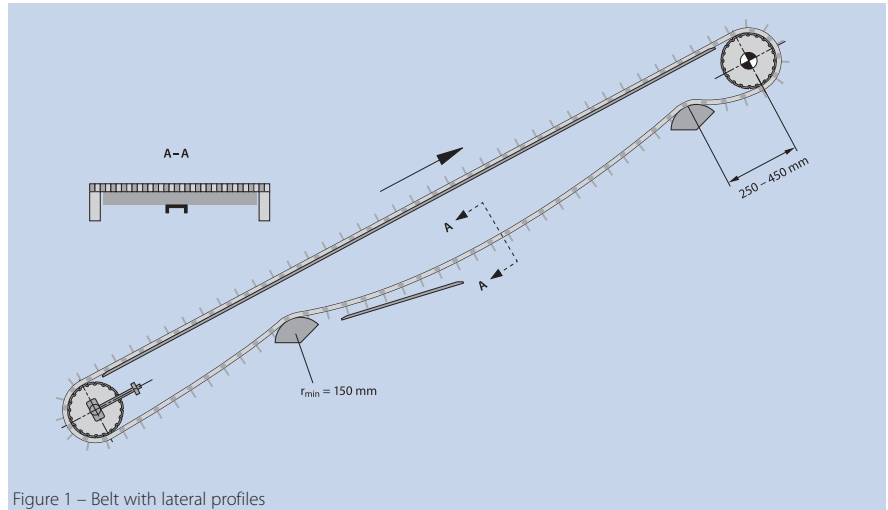

Figure 1 – Belt with lateral profiles

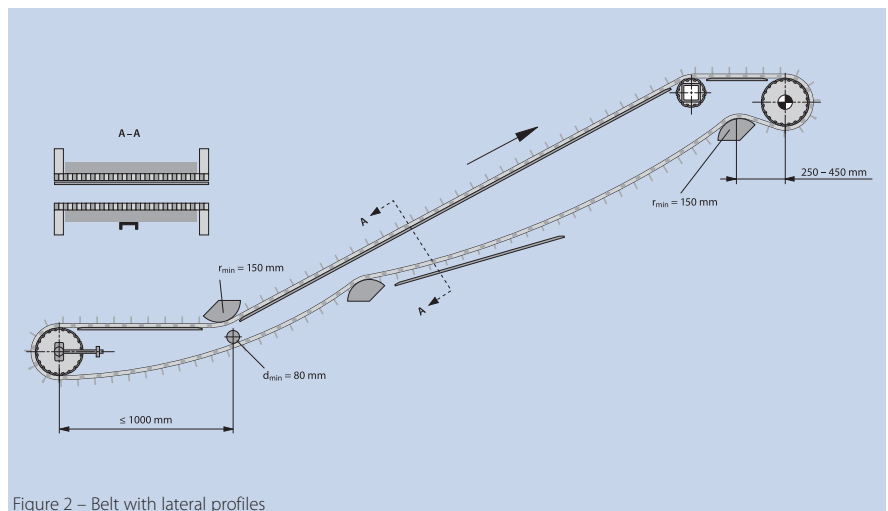

Figure 2 – Belt with lateral profiles

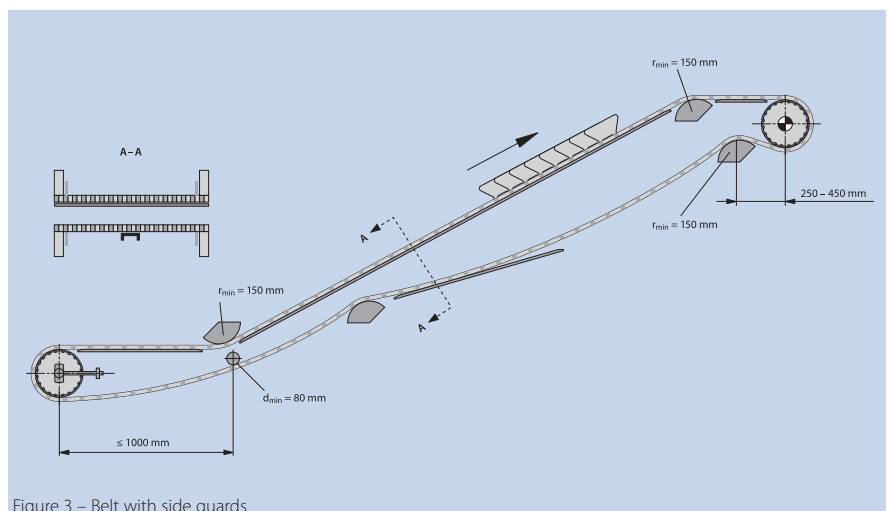

Figure 3 – Belt with side guards

Declined conveying

For this conveyor design, a tail drive unit is possible if there is an active load-dependent tension take-up at the lower idle shaft (e.g. gravity, spring or pneumatic). Otherwise the general recommendations given above apply here.

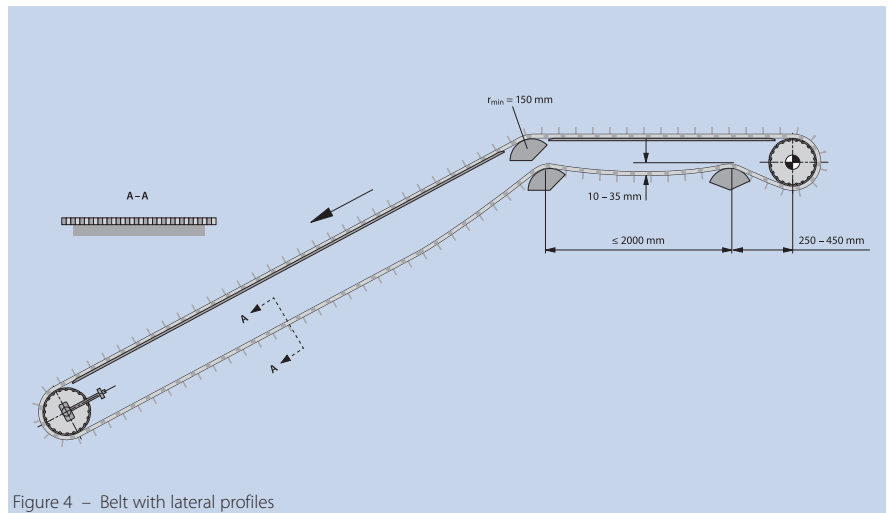
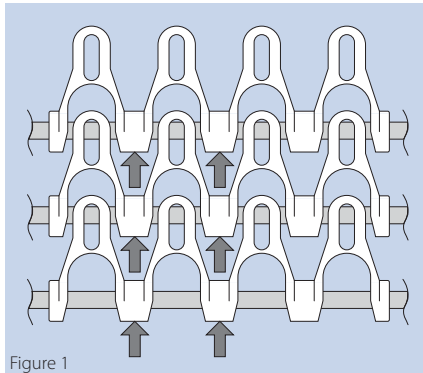

Figure 4 – Belt with lateral profiles

Curve conveyors

Meshing

The teeth must mesh into the modular belting in the areas marked by the arrows. (fig. 1)



Inner radius

Prolink inner radius r_{min} for curved belts
 $r_{min} = 2 \times b_0$

Belt tension

The three usual tensioning methods are possible to create the correct belt tension:

- Screw-operated take-up system
- Gravity take-up system
- Catenary sag on the return side near the drive drum

Geometries of curves

Please consult us if you cannot construct the conveyor according to the drawings because space is restricted.

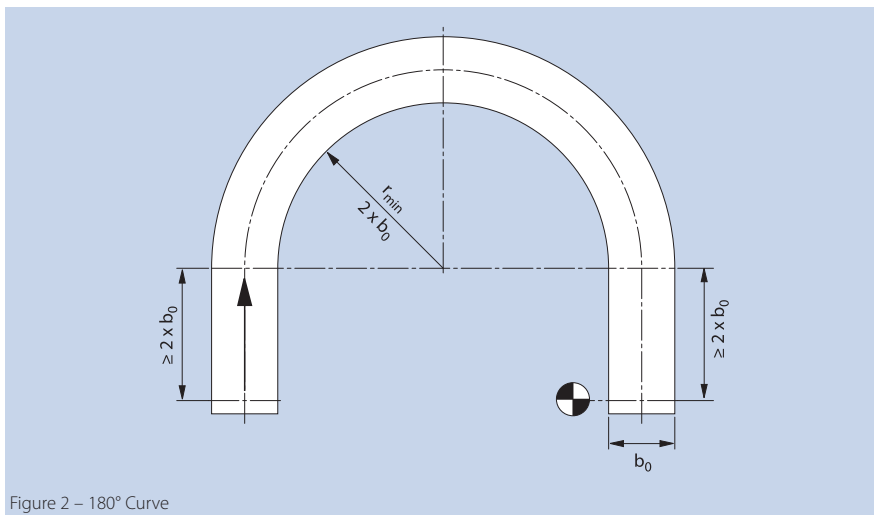

Figure 2 – 180° Curve

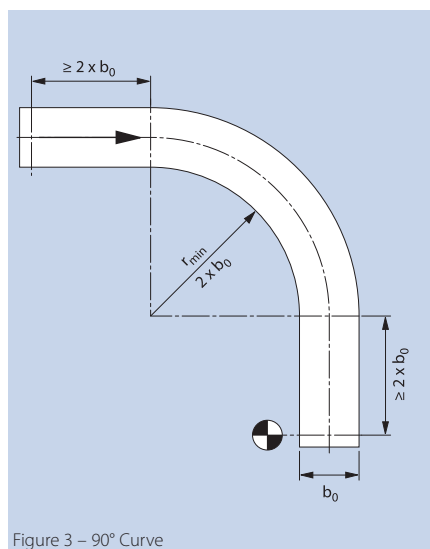

Figure 3 – 90° Curve

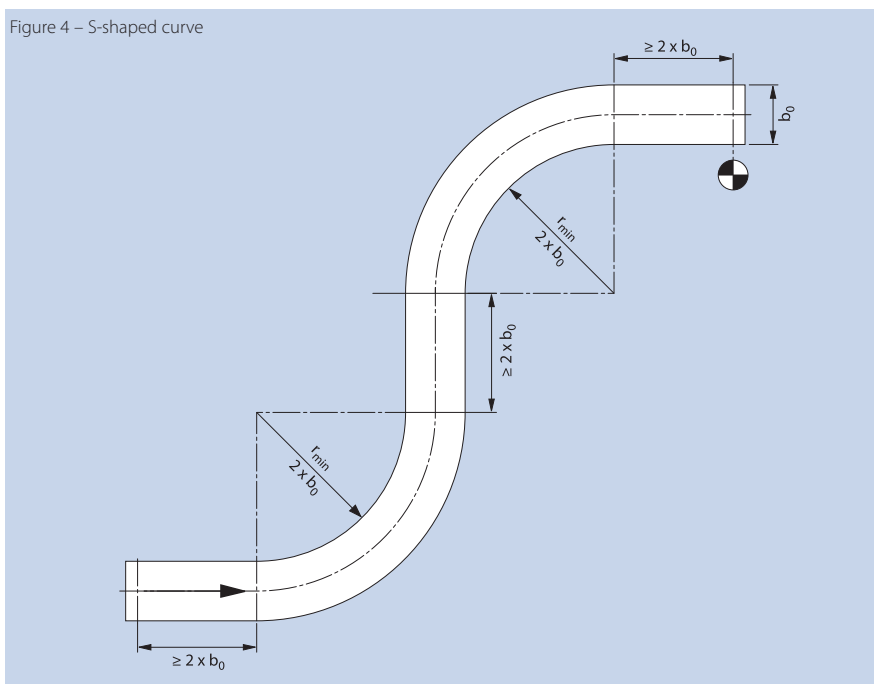

Figure 4 – S-shaped curve

Spiral conveyors

Possible conveyor designs

Fig. 1:
Example of declined conveying to join two production units with different heights.

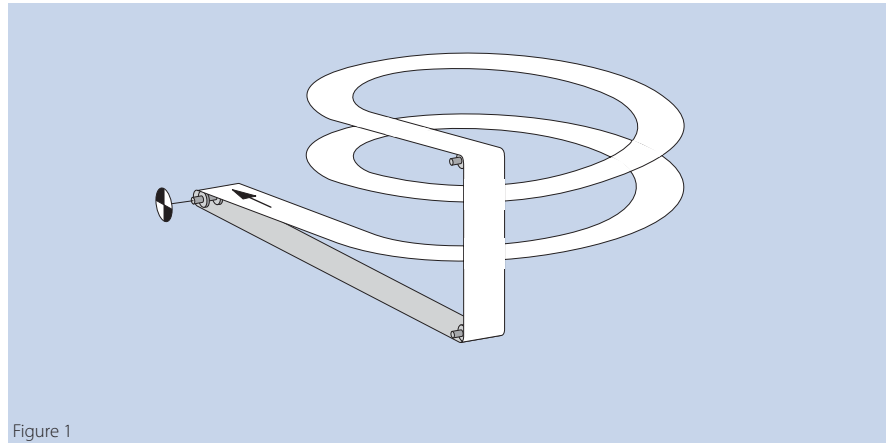

Figure 1

Fig. 2:
For inclined conveying, the drive unit must be located at the end of the curve at the top. Make sure that the arc of contact on the drive shaft is approx. 180°. This type of design (without driven inner cage) should not have more than 2 – 3 tiers.

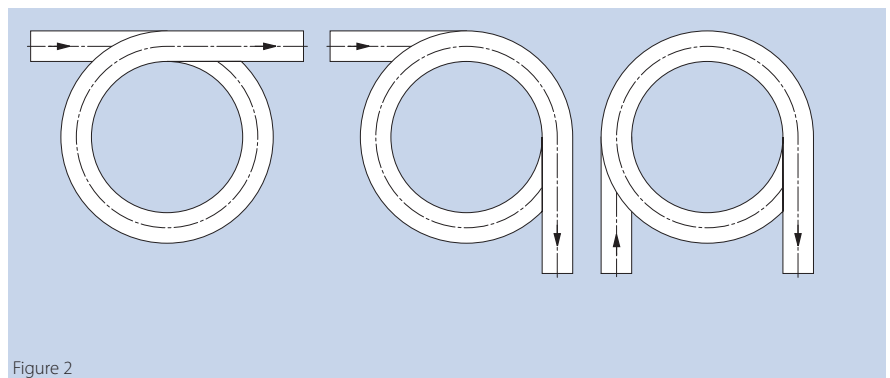

Figure 2

Fig. 3:
The main drive system is the driven inner cage, which as a rule consists of vertical rods. The curved belt is supported on the inner radius by the cage and is moved by traction between the belt and the cage. The direction of rotation of the cage determines whether the conveying is inclined or declined. The drive and tensioning unit depicted in the sketch provides the necessary belt tension. The speed of the motor must be coordinated with the speed of the cage drive. It should be possible to move the tensioning unit a distance corresponding to approx. 1% of the belt length. The belt can be supported by runners as described on page 2.

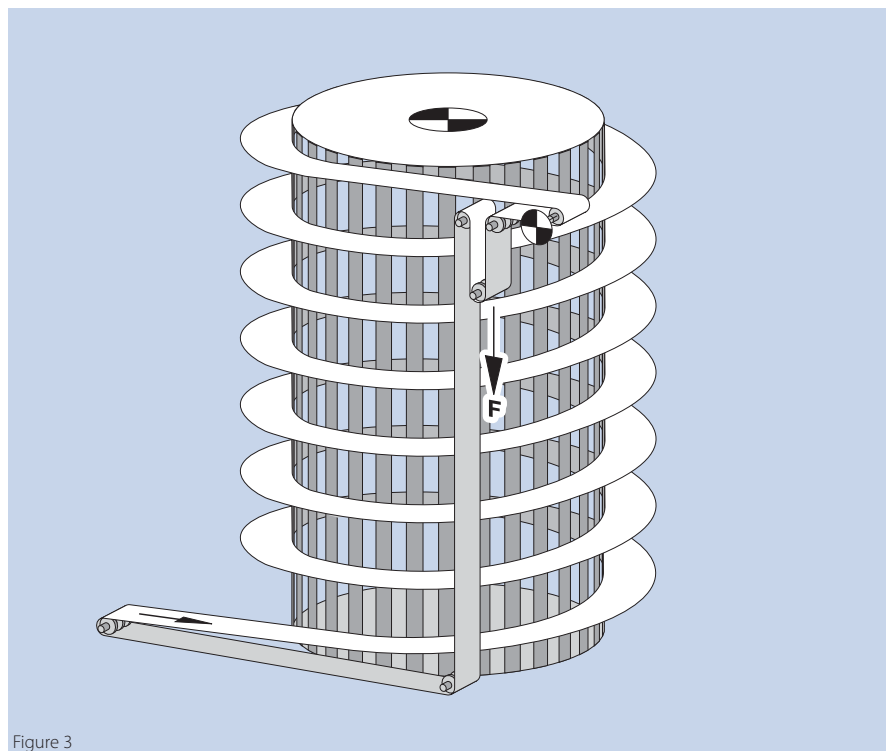

Figure 3

Further information

Effect of temperature

Plastics can expand or contract significantly when temperatures fluctuate. The construction engineer must make allowances for changes in belt lengths and widths if the operating temperature is not the same as the ambient temperature. Essentially, this affects the belt sag on the return side and the lateral clearance on the conveyor frame.

Material	Coefficient of thermal expansion a [mm/m/°C] *
Polyethylene PE	0.21
Polypropylene PP	0.16
Acetal POM	0.12
Polyamide PA	0.07
PE 500	0.16
PE 1000	0.16

* Average values for the permissible temperature range

Calculation of changes in length and width:

$$\Delta l = l_0 \cdot (t_2 - t_1) \cdot a$$

$$\Delta b = b_0 \cdot (t_2 - t_1) \cdot a$$

Calculation example:
Ambient temperature 20° C, the belt is used for the conveying of hot goods, resulting in an operating temperature of 90° C. Belt length 30 m, belt width 1 m, belt material polypropylene.

$$\Delta l = 30 \cdot (90 - 20) \cdot 0.16$$

$$\Delta l = 336 \text{ mm}$$

$$\Delta b = 1 \cdot (90 - 20) \cdot 0.12$$

$$\Delta b = 11.4 \text{ mm}$$

The increase in belt length of 336 mm is not insignificant which means that the return side must be designed in such a way that the additional belt sag is absorbed. In order to accommodate the increase in width, the conveyor frame must have a wider design.

When operating at temperatures below 0°-C, the length and width contract. This must also be accommodated in the conveyor design.

Δl = change in length in mm
+ = elongation
- = contraction

l_0 = belt length at initial temperature in m

b_0 = belt width at initial temperature in m

t_2 = operating temperature °C

t_1 = initial temperature °C

a = coefficient of thermal expansion mm/m/°C

Chordal action

What is known as chordal action is typical for all sprocket-driven belts, chains etc. The rise and fall of a module during the slewing motion cause changes in the linear speed of the belt. The number of teeth on sprocket is the decisive factor for these periodic fluctuations in speed.

As the number of teeth increases, the percentual change in speed decreases. In practice this means that the largest number of teeth possible must be used if the goods are not to tip or for other reasons an even belt speed is required.

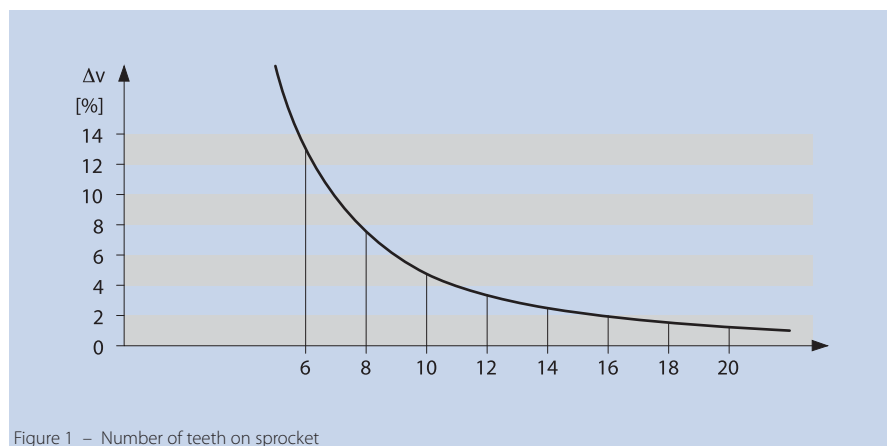

Figure 1 – Number of teeth on sprocket

Calculation

Key to the symbols

Designation	Symbols	Unit
Effective belt pull	F_U	N
Force determining belt selection	F_B	N
Shaft load	F_W	N
Calculated power at drive drum	P_A	kW
Coefficient of friction with accumulated goods	μ_{ST}	–
Coefficient of friction with skid plate	μ_T	–
Operational factor	C_1	–
Temperature factor	C_2	–
Stability factor	C_3	–
Acceleration due to gravity	g	9,81 m/s ²
Conveyor length	l_T	m
Height of lift	h_T	m
Mass of entire belt (see data sheet)	m_B	kg
Total load	m	kg
Mass of drive drum	m_w	kg
Angle of conveyor	α	°
Belt width	b_0	mm
Belt speed	v	m/min



Loading examples to determine the effective pull F_u

A

One of the three following formulae is used to calculate F_u , depending on the design of the conveyor.

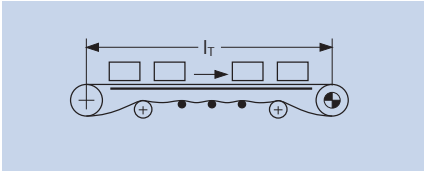

$$F_u = \mu_r \cdot g \cdot (m + m_b) \quad [N]$$

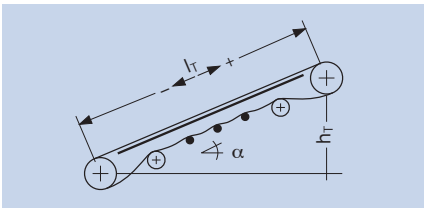

$$F_u = \mu_r \cdot g \cdot (m + m_b) + g \cdot m \cdot \sin \alpha \quad [N]$$

(+) inclined
(-) declined

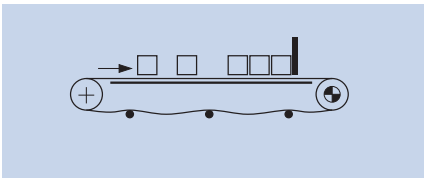

$$F_u = \mu_r \cdot g \cdot (m + m_b) + \mu_{st} \cdot g \cdot m \quad [N]$$

Mass of rotating parts on the return side was ignored.

Coefficients of friction μ_r (guidelines) between skid plate and belt

The figures stated have been established under ideal conditions. When operating under other conditions we recommend using higher friction coefficients

Skid plate made of	Belt material					
	PE wet	PE dry	PP wet	PP dry	POM wet	POM dry
PE 500	not recommended		0.12	0.10	0.08	0.08
PE 1000	0.33	0.25	0.14	0.12	0.10	0.10
Steel or stainless steel	0.15	0.15	0.25	0.25	0.18	0.18

Coefficients of friction μ_{st} (guidelines) between belt surface and accumulated goods

Container material	Belt material					
	PE wet	PE dry	PP wet	PP dry	POM wet	POM dry
Steel	0.15	0.15	0.25	0.25	0.18	0.18
Glass	0.15	0.12	0.12	0.10	0.12	0.11
Plastic	0.10	0.10	0.15	0.12	0.15	0.12

Force determining
belt selection F_B

B

$$F_B = F_U \cdot \frac{C_1}{C_2} \quad [N]$$

Operational factor C_1

	C_1
Smooth operating conditions (smooth start)	+ 1.0
Start-Stop-operation (start when loaded)	+ 0.2
Tail drive (push configuration)	+ 0.2
Belt speed greater than 30 m/min	+ 0.2
Inclined or swan-neck conveyor	+ 0.4
Total C_1	-----

Temperature factor C_2

Temperature [°C]	Belt material		
	PE	PP	POM
- 60	0.97	* -	-
- 40	0.96	-	0.98
- 20	0.92	* -	0.98
0	0.86	* -	0.97
+ 20	0.78	0.98	0.96
+ 40	0.70	0.95	0.96
+ 60	0.62	0.85	0.96
+ 80	-	0.65	0.75
+ 100	-	0.45	-

* below + 7 °C avoid jolts, ensure smooth start

Counter-checking the Prolink type selection

C

$$\frac{F_b}{b_0} = C_3 \leq C_3 \text{ max}$$

Factor C_3 max

Typ	PP [N/mm]	Material PE [N/mm]	POM [N/mm]
S1	30	18	40
S2	5	3	7
S3	12	6	16
S4	4	2	6
S5 CM 25, linear/curved module	18/1000 N	10/-	25/1800 N
S5 CM 50, linear/curved module	22/1600 N	12/-	30/2800 N
S6	-	20	30/36*
S7	18	40	60/80*

* depending on hinge pin and gear ring

Number of sprockets on the drive drum (guidelines)

Where centre distances are substantial, the number of drive sprockets still depends on the engagement ratio between teeth/module (i.e. on the belt length).

$C_3 \leq 20\%$

from C_3 max, the distance between the sprockets should then be approx. 160 mm.

$C_3 \leq 40\%$

from C_3 max, the distance between the sprockets should then be approx. 100 mm.

$C_3 \leq 60\%$

from C_3 max, the distance between the sprockets should then be approx. 80 mm.

$C_3 \leq 80\%$

from C_3 max, the distance between the sprockets should then be approx. 60 mm.

$C_3 > 80\%$

from C_3 max, please inquire.

Shaft load F_w

D

$$F_w \approx F_u \cdot C_1 + m_w \cdot g \quad [\text{N}]$$

Power requirement at the drive drum P_A

E

$$P_A = \frac{F_u \cdot v}{1000 \cdot 60} \quad v \text{ in m/min} \quad [\text{kW}]$$



Because our products are used in so many applications and because of the individual factors involved, our operating instructions, details and information on the suitability and use of the products are only general guidelines and do not absolve the ordering party from carrying out checks and tests themselves. When we provide technical support on the application, the ordering party bears the risk of the machinery functioning properly.

Forbo Siegling Service – anytime, anywhere

In the company group, Forbo Siegling employs more than 1900 people worldwide. Our production facilities are located in eight countries; you can find companies and agencies with stock and workshops in more than 50 countries. Forbo Siegling service centres provide qualified assistance at more than 300 locations throughout the world.